

**Directional Vaned 13-Inch Rotor with
Forged Aluminum Caliper**



SRP Series Rotor shown

Available with slotted,
uncoated, GT Series Rotor

Front Disc Brakes - Performance

Our front disc brake kit features rear mounted, fixed, four- or six-piston calipers and 13" x 1.10" directional vaned, slotted rotors* with billet aluminum hats and hubs. Standard black calipers can be upgraded to optional red-powder-coated finish. The bolt together hat, hub, rotor assembly allows worn or damaged components to be replaced easily and economically. Standard GT rotors feature an uncoated surface, ideal for extended high temperature operation. Kits can also be upgraded to cross-drilled and black E-coated SRP rotors. Our enhanced friction ceramic formula brake pads provide smooth engagement, long service life, with low noise and brake dust levels for performance driving applications. The kit is designed for use with OEM Mustang disc brake spindles with crossbolt mounting method from 1968 through 1973 and requires 17" or larger wheels.

*- Kit '140-9482' packaged with 12.19" x .1.25" rotors.

Forged Superlite Caliper

Our Mustang brake kit uses Wilwood's Forged Superlite SL4, 4-piston lug mount, or SL6R, 6-piston radial mount, aluminum calipers for superior rigidity, enhanced braking performance and pedal feel. These calipers use a closed end design that is further strengthened by five steel bridge bolts extending through the caliper body and directly across the brake pads. Stress flow forging and smooth surface transitions help to eliminate stress points and reduce overall caliper deflection.



Optional red powder-coated caliper

Calipers use one-piece, stainless steel pistons and high temperature, square faced bore seals. Stainless steel slows heat transfer to the brake fluid and improves the system's resistance to heat induced pedal fade. This reduction in heat also increases the service life of the fluid and seals. The four individual pistons apply pressure against both sides of the rotor. Caliper fluid requirements are matched to the output capabilities of commonly used factory master cylinders for comfortable performance in a wide range of applications.

Superlite calipers are trouble-free and service friendly. Vibration dampening stainless steel bridge plate inserts protect the caliper body from wear caused by pad movement, greatly extending service life. Dampened external fluid tubes are routed through recessed pockets to keep clear of debris and reduce the potential of vibration induced wear at the fittings. Two-piece bleed screws are easily accessed at the top of each side of the caliper body and eliminate direct wear to the aluminum body. Brake pads are also changed easily by simply removing the center bridge bolt and sliding the pads out.

High Performance Rotors



The kit comes standard with GT series directional vaned, asymmetrical slotted, rotors measuring 12.19" x 1.25" or 13" x 1.10". The GT rotors come uncoated and can withstand extreme operating temperatures for extended periods of time; ideal for high performance racing applications. For more eye-catching high-end street performance, rotors can be upgraded to a SRP series directional vaned, cross-drilled, slotted, black E-coated rotors. To

maximize cooling surface area, forty-eight individual air passages are cast internally into each rotor. Air passages or vanes are directional and curved for increased airflow over standard straight vented rotor designs. The slotted surface and optionally available cross-drilled holes improve pad to rotor contact by wiping the pad clean and allowing brake dust and gases to be easily exhausted.



SRP Rotor
(140-XXXX-D)



GT Rotor
(140-XXXX)

Billet Aluminum Hat and Hub

Separate billet aluminum hats and hubs reduce unnecessary weight and allow components to be easily replaced if damaged or worn. Hats use a solid wall, concave design to improve rotor stability. Their black anodized finish prevents oxidation and resists scratching.



Rotors and hats are secured by safety wire drilled 12-point bolts in a 12-bolt configuration. Hubs are silver anodized matte finish with matching screw-on cap with O-ring seal. Assemblies include both 4-1/2" and 4-3/4" five lug bolt patterns with 1/2" x 2" wheel studs or optional 1/2" x 3" studs. Tapered wheel bearings and seals also included.



Exploded Diagram

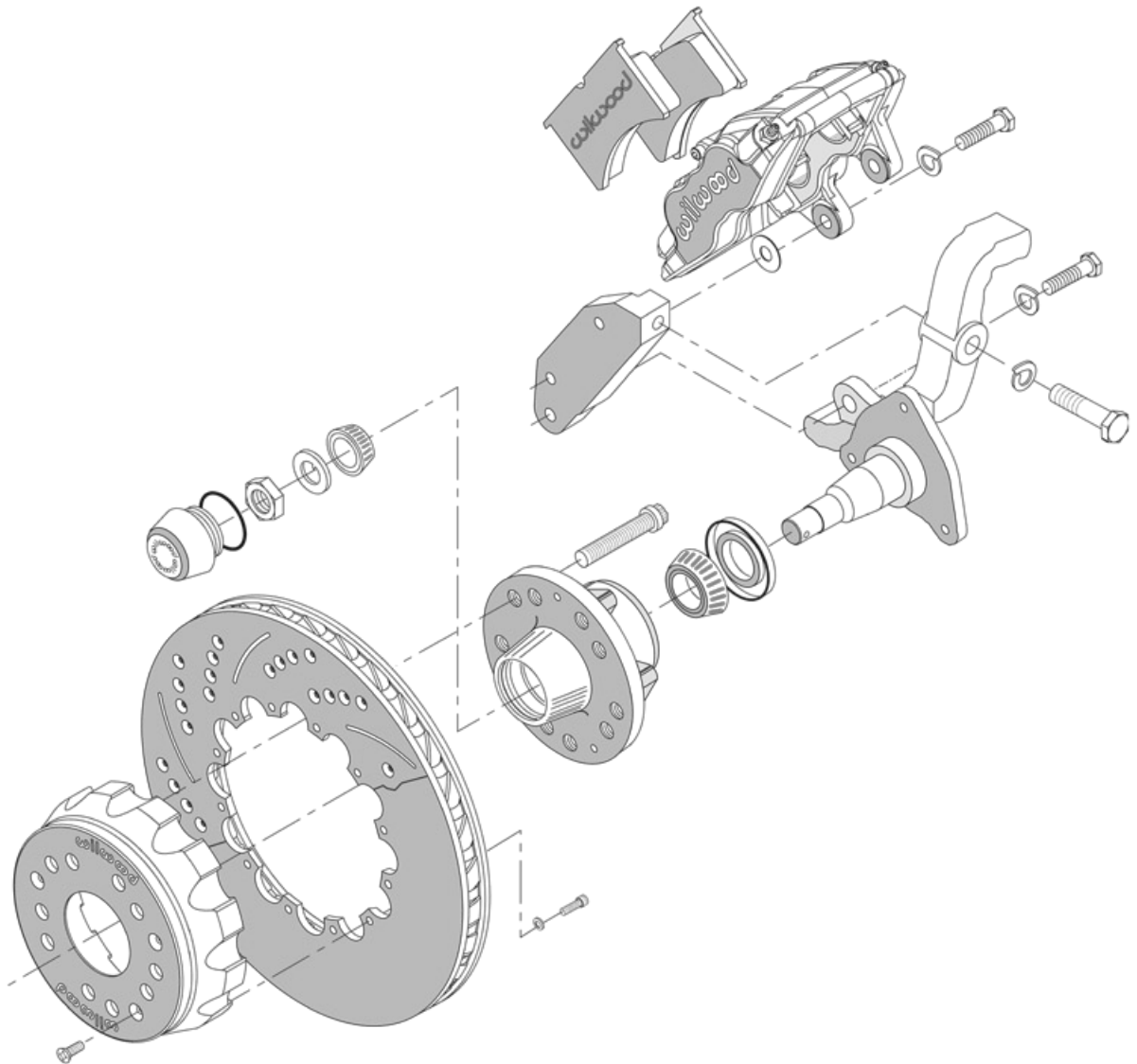

Applications

Make	Model	Year	Spindle	Rotor Size	GT 4-piston	SRP 4-piston	GT 6-piston	SRP 6-piston
					\$1424.00*	\$1525.00*	\$1700.00*	\$1803.00*
Ford	Fairlane	1968-1969	Disc	13.00 x 1.10	140-9501	140-9501-D	140-10219	140-10219-D
		1970-1971	Disc	13.00 x 1.10	140-9189	140-9189-D	140-10220	140-10220-D
	Falcon	1968-1970	Disc	13.00 x 1.10	140-9501	140-9501-D	140-10219	140-10219-D
	Mustang	1968-1969 ¹	Disc	13.00 x 1.10	140-9501	140-9501-D	140-10219	140-10219-D
		1970-1973 ²	Disc	13.00 x 1.10	140-9189	140-9189-D	140-10220	140-10220-D
	Mustang (GT 350/500)	1970	Disc	13.00 x 1.10	140-9501	140-9501-D	140-10219	140-10219-D
	Mustang II	1974-1978	Disc/Drum	12.19 x 1.25	140-9482	N/A	N/A	N/A
	Pinto	1974-1980	Disc/Drum	12.19 x 1.25	140-9482	N/A	N/A	N/A
	Ranchero	1968-1969	Disc	13.00 x 1.10	140-9501	140-9501-D	140-10219	140-10219-D
		1970-1971	Disc	13.00 x 1.10	140-9189	140-9189-D	140-10220	140-10220-D
Torino	1968-1969	Disc	13.00 x 1.10	140-9501	140-9501-D	140-10219	140-10219-D	
	1970-1971	Disc	13.00 x 1.10	140-9189	140-9189-D	140-10220	140-10220-D	
Mercury	Comet	1968-1969	Disc	13.00 x 1.10	140-9501	140-9501-D	140-10219	140-10219-D
		1970	Disc	13.00 x 1.10	140-9189	140-9189-D	140-10220	140-10220-D
	Cougar	1968-1969	Disc	13.00 x 1.10	140-9501	140-9501-D	140-10219	140-10219-D
		1970-1973	Disc	13.00 x 1.10	140-9189	140-9189-D	140-10220	140-10220-D
	Montego	1968-1969	Disc	13.00 x 1.10	140-9501	140-9501-D	140-10219	140-10219-D
1970-1971		Disc	13.00 x 1.10	140-9189	140-9189-D	140-10220	140-10220-D	

Footnotes:

*	Optional red caliper, add \$155
1	Excludes Boss 302/429
2	Excludes Shelby GT 350/500

All prices subject to change. Current pricing available at www.cachassisworks.com.



Chris Alston's Chassisworks, Inc.
8661 Younger Creek Drive
Sacramento, CA 95828

Order: 800-722-2269
Tech: 916-388-0288
Fax: 916-388-0295

sales@cachassisworks.com
www.cachassisworks.com