



## Leaf Spring Plates

### Direct Replacement Leaf Spring Plates with Integrated Tie Down Loop



Our direct replacement leaf spring plates feature an integrated tie-down loop for added convenience when securing a vehicle to a trailer. The oversized loop measures 1.5" by 3.7" allowing plenty of clearance for heavy-duty strap hooks. The plate is manufactured from 3/16" plate steel with CNC press brake formed sides creating the strongest welded joints possible. Radiused gussets extend downward to support the loop at its lower corners and also improve structural stability at the shock mount tab. To give more clearance for brake lines on common 9" housing conversions, the shock mount position has been moved slightly forward. The shock tab uses heavier 1/4" thick steel and features a 0.85" diameter mounting hole for use with aftermarket shock bushings. The plates are designed for 2-1/2" wide leaf springs and can be installed on various make and model vehicles. Slotted holes enable the use of 7/16" or 1/2" U-bolts and 2-1/4" to 3-1/4" diameter axle tubes. For appearance, all corner welds are ground smooth adding to the overall curved flowing design. Zinc plating enhances the quality finish and provides protection against corrosion.

#### Features

- Fits 2-1/2" wide leaf springs
- Accepts 7/16" and 1/2" U-bolts
- Can be used with 2-1/4" to 3-1/4" axle tubes
- Integrated tie down strap
- Relocated shock mount
- Available standard and staggered mount shocks

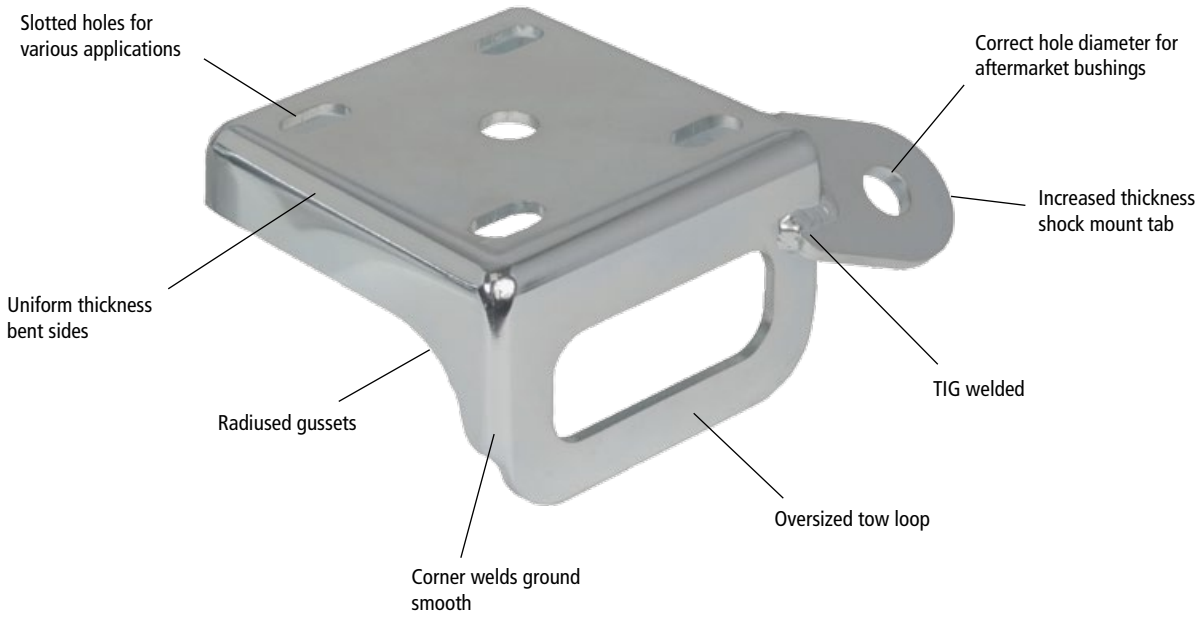

## Applications

Model	Year	Standard	Staggered
		\$135. <sup>00</sup>	\$135. <sup>00</sup>
Cougar	1967-1973	TCP LSP-01	TCP LSP-02
Mustang	1965-1978	TCP LSP-01	TCP LSP-02

Additional Applications: Requires 2-1/2" wide leaf springs with 2-1/4" to 3-1/4" diameter axle tubes

All prices subject to change. Current pricing available at [www.cachassisworks.com](http://www.cachassisworks.com).



Total Control Products  
8661 Younger Creek Drive - Sacramento, CA 95828  
A Chris Alston's Chassisworks, Inc. Brand

Order: 800-722-2269  
Tech: 916-388-0288  
Fax: 916-388-0295

[tcpsales@cachassisworks.com](mailto:tcpsales@cachassisworks.com)  
[tcptech@cachassisworks.com](mailto:tcptech@cachassisworks.com)  
[www.totalcontrolproducts.com](http://www.totalcontrolproducts.com)