



350 S. St. Charles St. Jasper, In. 47546 Ph. 812.482.2932 Fax 812.634.6632  
on the internet: [www.ridetech.com](http://www.ridetech.com)

## ARC4000L LevelPro Compressor System

- 1 ARC5001 Compressor
- 1 ARV4000 4 way RidePro air valve assembly
- 1 F9127 3 gallon tank
- 1 CON7001 LevelPro control system
- 5 CON7100 Air pressure sensor
- 4 SEN001 Height sensor
- 4 SEN002 Hardware kit for height sensor (includes the following)
  - 1 Steel linkage rod
  - 2 Rubber rod ends
  - 2 Hose clamps
  - 2 1/4" sensor bolts w/ Nyloc nuts & flat washers
  - 1 Mounting tab
- 1 WIR8000 Air valve wiring harness
- 1 WIR8300 Group wiring harness
- 1 WIR8400 Air pressure sensor wiring harness
- 1 WIR8500 Compressor relay wiring harness
- 2 ARL2000 30 ft. roll of 1/4" DOT airline
- 4 FIT4201 1/4"npt x 1/4"tube elbow fitting for air springs
- 7 FIT4000 1/4"npt x 1/4" tube straight fitting for air valve and tank
- 1 FIT2150 1/8"npt female x 1/4" tube straight fitting for compressor
- 1 FIT7003 1/8"npt nipple (install between FIT2150 & compressor)
- 1 FIT7004 1/4"npt plug to plug extra supply port
- 2 FIT6800 3/8"npt x 1/4" tube 90 degree air fitting for air tank
- 1 Compressor and Air Tank Template

# LevelPRO™

by Air Ride Technologies

## Table of Contents

• Plumbing & Wiring Diagram	page 3
• Product Installation Guide	pages 4-7
• Detailed Wiring Harness Guide	page 7
• Initial System Setup	page 8
• Programming Presets	page 8
• Activating “Ride Height on Start” Feature	page 9
• Altering the Preset Speed	page 9
• Changing the Display View Options	page 9
• Changing the Display Intensity	page 10
• Changing the Button Intensity	page 10
• Viewing Tank Pressure	page 10
• Changing the Tank Pressure Trigger	page 11
• Low Pressure Safety Override	page 11
• Operating the Remote Control	page 12
• Troubleshooting Guide	page 13

# ARC4000L Wiring Diagram

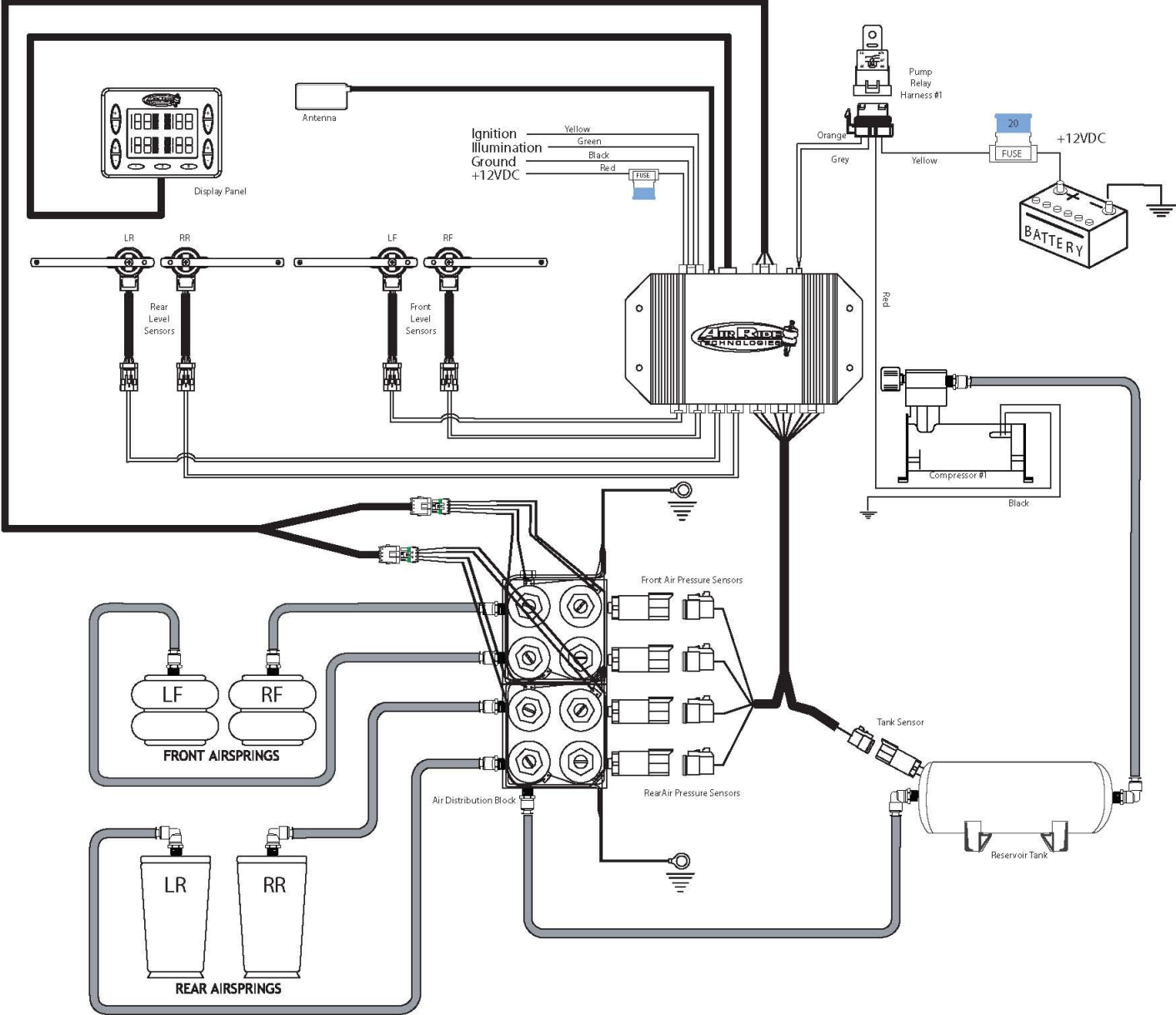



350 S. St. Charles St. Jasper, In. 47546 Ph. 812.482.2932 Fax 812.634.6632  
on the internet: [www.ridetech.com](http://www.ridetech.com)

## ARC4000L Compressor System Instructions

These are some general guidelines to follow when installing your new LevelPro air control system. Depending on the vehicle there are many different ways to plumb the system. Start out by planning a lay out of where you want everything to be mounted. Typically we try to keep the compressor, solenoids, tank, and sending units in a central location, but they can be separated to suit your needs.

### Mounting the Compressor & Relay

- **Remove the negative battery cable before beginning installation.**
- All of our compressors are sealed for moisture and dust resistance so they can be mounted anywhere on the vehicle. Although it is best to mount it in a place out of direct contact with rain and snow. It is OK to mount it underneath the vehicle but keep it inside the frame rails away from water and debris thrown off the tire.
- This is a dry compressor; therefore it is maintenance free and can be mounted in any position.
- It is best if mounted to something solid to reduce vibration and noise. If mounting it to sheet metal or the bed of a truck use sound deadening material between the compressor and the mounting surface.
- Use the rubber grommets supplied on the feet of the compressor to reduce vibration.
- A template is supplied to aid in drilling the holes. Check template with compressor before drilling the holes
- A main power wire of 10ga. or larger will be needed to supply the compressor. It will attach to the Yellow wire on the relay. The Red wire on the relay will go to the Red wire on the compressor. The black wire on the compressor should be attached to a clean ground, usually the frame. The small gray and orange wires will plug into the RL1 port on the ECU. If you are running two compressors you will need an additional relay that will plug into the RL2 port.

### Mounting the Air Tank

- The air tank can be mounted anywhere on the vehicle in any position.
- A template is supplied to aid in drilling the holes. Check the template with the tank before drilling the holes.
- If your air system is used frequently you may want to remove the tank once a season to drain any excessive accumulation of water.
- There is an 1/8" port in the tank that will accept the tank pressure sensor.

## Mounting the RidePro Air Valves

- The valves, like the compressor, are sealed and can be mounted in the same locations. Although if the vehicle will be exposed to freezing temperatures it is a good idea to mount them in the engine bay if possible to reduce the possibility of freezing.
- They can be mounted in any position.
- Mount the valves higher than the tank to avoid moisture build up. This could cause the air pressure sensors to give a faulty reading.
- Attach the ground strap to a good, clean ground (preferably the frame).
- The exhaust port will be left open.
- The valve is held closed with the pressure in the tank. If tank pressure drops below air spring pressure they will equalize deflating all 4 air springs.

## Routing the Airline and Fittings

- Make all airline cuts with a razor or tubing cutter. It must be clean and straight or it will not seal.
- All fittings are DOT approved push-to-connect style. They are very simple to use and are reusable. Firmly push the airline into the fitting to attach. To release the airline pull the collar on the fitting back towards the fitting and pull the airline out.
- Use thread sealant on all fittings.
- Do not over tighten the fittings. This could result in breaking the fitting or damaging the air spring.
- All of our airlines are DOT approved so they are very strong. But keep them away from any sharp edges. Also when passing through a hole in the frame use a grommet.
- Keep away from intense heat including mufflers and exhaust manifolds.
- Use zip ties or other fasteners to secure the airline.

## Mounting the Air Pressure Sensors

- The air pressure sensors are installed directly into the air valve in the port marked "Gauge". Be sure to use a thread sealant to avoid leaks.
- If you are mounting the air valve to a flat plate you will need to use the 1/4" aluminum spacer to create clearance for the air pressure sensors.
- The tank pressure sensor may be installed in the tank as shown in the diagram or in the unused "Supply" port of the air valve.
- These sensors are voltage based and do not need to be grounded.

## Mounting the Height Sensors (RidePro E2 systems will not use height sensors)

- The LevelPro system uses 4 ride height sensors, 1 at each wheel. They are weather proof and may be mounted in any position as well as "clocked" in any position. (There is not a difference between the left and right sensors.) The arms can be removed and placed in 4 different positions.
- The ride height sensors have a 180-degree range of movement, but only a 90-degree range of "electrical authority". This means that they will only read through the middle 90 degrees of their travel. As you can see in the diagram below the sensor has indexing tabs that indicate its center position as well as the travel limits of its authority. On the compression and extension the tab will ALMOST align with the opposite hole. When mounting the ride height sensor make sure it does not exceed these limits during the suspension travel. If the electrical range of travel is exceeded the system may function erratically or not at all. Also note that if the sensor has very little travel the LevelPro system

may not perform to its potential. It may be necessary to shorten the sensor arm to increase travel.

- During the installation you may need to try different attachment points to the suspension to insure proper sensor travel range. The sensor arms can be easily removed and re-clocked to make your installation easier. The sensor arm and linkage can be modified by cutting and/or bending to aid installation. It may be necessary to shorten the sensor arm to achieve proper sensor travel, especially on an independent suspension.
- Make sure that the sensors, sensor arms, and sensor linkages are not damaged during suspension and/or steering movement.

**Compressed**

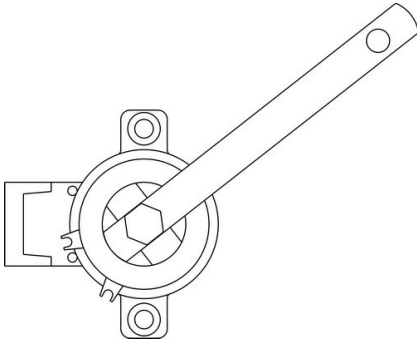

**Ride Height**

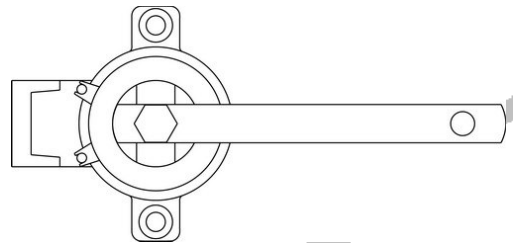

**Extended**

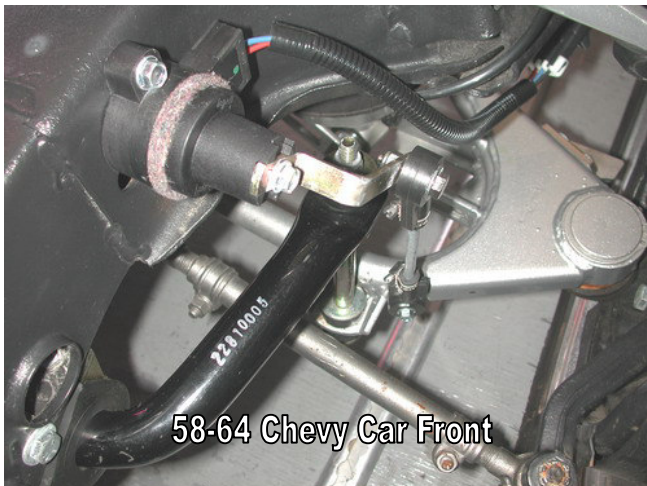
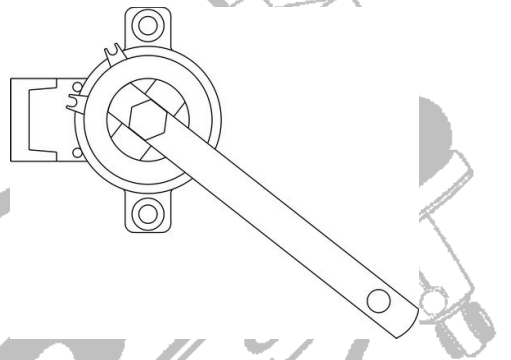

## Mounting the ECU (Electronic Control Unit) & Control Panel

- The control panel should be accessible from the drivers seat and may be surface mounted, flush mounted, or left unmounted. A larger faceplate is included to allow proper flush mounting of the control panel.
- 6ft. extension cables for the control panel harness are available if needed.
- The ECU should be mounted in the trunk or in the passenger compartment to avoid exposure to heat or moisture. Wiring will be as follows.

### 1. Main Power Harness

Red wire	Constant 12 volt
Black	A clean chassis ground
Yellow	Ignition (12 volts only when the key is on)
Green	Illumination (12 volts only when lights are on, this will dim the gauges)

### 2. Air Pressure Sensor Harness

This harness has 3 plugs; one 4 pin plug for the Tank pressure and two 6 pin plugs for the air spring pressures. The tank pressure harness will connect to the plug on the ECU labeled The air spring pressure connectors are labeled on the ECU as APRF (Air Pressure Right Front) & APLF. The plug with the Blue wire will connect to the APRF and the plug with the green wire will connect to the APLF. The other end is labeled accordingly. It may be necessary to lengthen or shorten this harness.

### 3. Height Sensor Harness

There are 4 separate harnesses for the height sensors. They are labeled per corner and the ECU is marked; LSLF (Level Sensor Left Front) Etc.

### 4. Air Valve Harness

This harness has 8 pins and will plug into the connector labeled "Driver". The other end has two black Weather Pack connectors that will plug directly into the RidePro air valves. These plugs are labeled for "Front" and "Rear". If you have the Big Red valves an adapter harness is needed. If you are not using our valves refer to the list below for proper wiring.

#### Front Harness

- |               |                        |
|---------------|------------------------|
| • Orange wire | Left inflate solenoid  |
| • Red wire    | Left deflate solenoid  |
| • Black wire  | Right inflate solenoid |
| • Blue wire   | Right deflate solenoid |

#### Rear Harness

- |               |                        |
|---------------|------------------------|
| • Orange wire | Left inflate solenoid  |
| • Red wire    | Left deflate solenoid  |
| • Black wire  | Right inflate solenoid |
| • Blue wire   | Right deflate solenoid |

## Initial System Set-Up:

### **Programming Ride Height Sensors:** [for LEVELPRO only]

Upon initial installation the ECU needs to be programmed to learn the specific characteristics of the ride height sensors being used. This short initial programming sequence avoids the requirement for “position specific” sensors. (If you are not using ride height sensors, you do not need to program the ECU. The air pressure sensors are preprogrammed from the factory.) This will not program the presets.

- Step 1 - Press and hold the Air Ride Logo Programming Button for 3 seconds. This will illuminate the programming button and will activate the programming sequence.
- Step 2 - Manually raise the suspension to full extension. This can be accomplished via the manual inflate buttons on the control panel OR by external means such as a floor jack or lift. If it takes more than 10 seconds to raise the vehicle to its maximum height via the air suspension you will need to use a floor jack or lift to assist. The goal is to “teach” the ECU the highest position AND the correct direction of travel of the ride height sensors. TIP: Before initiating the programming sequence raise the vehicle to ride height and let the compressor[s] refill the reservoir tank. This will significantly shorten the time it takes to raise the vehicle to complete extension after initiating the programming sequence. NOTE: There must be some suspension movement to achieve full extension to teach the ECU the correct direction of travel of the ride height sensors.
- Step 3 - Press the Preset # 3 button. This will illuminate the #3 button and the height indicator bars.
- Step 4 - Lower the vehicle to its lowest height. This can be accomplished via the air suspension or with a floor jack or lift. The goal is to “tech” the ECU the lowest position of the ride height sensors.
- Step 5 - Press preset # 1. This will illuminate the #1 preset button and one height indicator bar.
- Step 6 - Press the Air Ride Logo Programming button to finish the programming sequence. [If no buttons are pushed for 10 seconds the sequence will finish automatically].

## Display Set-up:

### **To Set Preset #1, 2, or 3:**

These presets typically correlate to Low, Highway, and High ride heights, but can be programmed to any desired position. NOTE: When the “ride height on start” feature is engaged the system will automatically select preset #2 when the vehicle is started. Therefore it is recommended that you program preset #2 to be your highway ride height.

- Step 1 - Set the vehicle to the desired ride height using the manual inflate/deflate buttons.
- Step 2 - Press and hold Preset Button #1, 2, or 3 for 5 seconds. (Just like setting a radio station in your car).  
The corresponding button will light after 3 seconds, then flash after 5 seconds as long as it is pressed to indicate the setting has been learned.  
Flashing will cease once the button is released.

### **To Turn “Ride Height on Start” feature On or Off:**

When this feature is enabled the vehicle will return to Preset #2 any time the ignition is turned On.

The ride height on start feature is enabled when the Air Ride Logo button and the manual inflate/deflate buttons are illuminated. Simply press the Air Ride Logo programming button to engage or disengage this feature.

### **To alter the Inflate and Deflate Preset Speed of the system**

You may increase or decrease the length of time the unit will inflate or deflate to make the system work faster, slower, or more accurately. There are five levels with level 1 being the slowest, but most accurate, and level 5 being the fastest.

- Step 1 - Press and hold the Air Ride Logo Button and #2 simultaneously for 3 seconds.
  - The tank pressure will be displayed in the Left Front display area.
- Step 2 - Press and hold Preset buttons #1 and 3 simultaneously.
  - Preset buttons #1 and 3 are illuminated.
  - The Preset Speed is indicated in the left front air pressure area.
- Step 3 - Press the left front inflate (+) button to increase the speed of the system.
- Step 4 - Press the left front deflate (-) button to decrease the speed of the system.
- Step 5 - Normal operation will resume:
  - 10 seconds after the last button is pressed.
  - OR
  - If the Air Ride Logo Button is pressed.

### **To change display view options:**

You can choose between three display view options; numeric (air pressure), bar graph (level sensor), and numeric with bar graph [both].

1-Press and hold the Air Ride Logo Button for 3 seconds.

-The Air Ride Logo Button is illuminated.

2-Press Preset Button #1, 2, or 3 to change display settings.

Button #1: Numeric and bar graph

Button #2: Numeric only

Button #3: Bar graph only

-When a Preset Button is pressed, that particular button will be lit, and the corresponding display will be shown.

3-Normal operation will resume:

-10 seconds after the last button is pressed

OR

-If the Air Ride Logo Button is pressed

### **To Activate the Presets**

After programming the presets they can be activated by press either 1,2 or 3 for three seconds. Be careful not to hold it too long. If you hold it for 5 seconds it will reprogram that preset.

### **To change the display intensity:**

This will alter the intensity of the VFD display.

- 1-Press and hold the Air Ride Logo Button for 3 seconds
  - The Air Ride Logo Button is illuminated
- 2-Press Preset buttons #1 and 3 simultaneously
  - Preset buttons #1 and 3 are illuminated
  - The Normal Display screen remains displayed
- 3-Press the Right Front inflate (+) button to increase the display intensity
- 4-Press the Right Front deflate (-) button to decrease the display intensity
- 5-Normal operation will resume:
  - 10 seconds after the last button is pressed
  - OR
  - If the Air Ride Logo Button is pressed

### **To change the button backlight intensity:**

This will alter the intensity of the LED backlights for the buttons.

- 1-Press and hold the Air Ride Logo Button for 3 seconds
  - The Air Ride Logo Button is illuminated
- 2-Press Preset buttons #1 and 3 simultaneously
  - Preset buttons #1 and 3 are illuminated
  - The Normal Display screen remains displayed
- 3-Press the Left Front inflate (+) button to increase the backlight intensity
- 4-Press the Left Front deflate (-) button to decrease the backlight intensity
- 5-Normal operation will resume:
  - 10 seconds after the last button is pressed
  - OR
  - If the Air Ride Logo Button is pressed

### **To view tank pressure:**

- 1-Press and hold the Air Ride Logo Button and #2 simultaneously for 3 seconds
  - The tank pressure will be displayed in the Left Front display area
- 3-Normal operation will resume:
  - When the Air Ride Logo Button is pressed

### **To change Tank Pressure Trigger:**

You can change the pressure at which the pump(s) turn On. (between 135 and 150 psi.) This allows you to decide whether your pump(s) should run less often for a longer amount of time, or if they should run more often for a shorter amount of time.

NOTE: When using two pumps the secondary pump will activate 3 seconds after the first pump to lower inrush current draw on your electrical system.

1-Press and hold the Air Ride Logo Button and #2 simultaneously for 3 seconds

-The tank pressure will be displayed in the Left Front display area

3-Press and hold Preset buttons #1 and 3 simultaneously

-Preset buttons #1 and 3 are illuminated

-The Tank Pressure Trigger is indicated in the right front air pressure area

5-Press the right front inflate (+) button to increase the pressure trigger.

6-Press the right front deflate (-) button to decrease the pressure trigger.

7-Normal operation will resume:

-10 seconds after the last button is pressed

OR

-If the Air Ride Logo Button is pressed

### **To turn the Low Pressure Safety Override Feature On/Off:**

When enabled this feature will disable preset functionality when the tank pressure is below a preset limit.

Example: If you were to press the Preset #2 button to attain ride height and the tank pressure went below the preset limit, the system will suspend the action and alert the driver by flashing the inflate/deflate buttons and the Air Ride Logo button until the tank pressure is at a safe level. Once the pressure in the tank is at a safe level, the unit resumes it's action of traveling to Preset #2. If this function is disabled and the tank pressure drops below the airspring pressure, the vehicle may actually deflate instead of inflate.

NOTE: If this situation occurs frequently it may indicate one or more problems.

1. There may be a leak in the system that allows the tank pressure to drop below the activation threshold. 2. Vehicles requiring a higher air pressure to achieve ride height may need a larger or additional tank to operate properly.

1-Press and hold the Air Ride Logo Button and #2 simultaneously for 3 seconds

-The tank pressure will be displayed in the Left Front display area

3-Press and hold Preset buttons #1 and 3 simultaneously

-Preset buttons #1 and 3 are illuminated

-The Safety Feature is indicated in the right rear air pressure area

5-Press the right rear inflate (+) button to turn the Safety Feature On

6-Press the right rear deflate (-) button to turn the Safety Feature Off

7-Normal operation will resume 10 seconds after the last button is pressed OR If the Air Ride Logo Button is pressed

## Remotes:

Remote Buttons:

Button #1: Correlates to Preset #1.

Button #2: Correlates to Preset #2.

Button #3: Correlates to Preset #3.

**Note:** The remote will only work with the ignition OFF.

\*\*\*3 remote maximum\*\*\*

### To Learn Remotes: (Ignition On)

- Step 1 - Press the Air Ride Logo Button 3 times.
  - The Air Ride Logo Button is illuminated.
- Step 2 - Press button #1 on the first remote.
  - The Air Ride Logo Button will flash off momentarily.
- Step 3 - Press button #1 on the second remote.
  - The Air Ride Logo Button will flash off momentarily.
- Step 4 - Press button #1 on the third remote.
  - The Air Ride Logo Button will flash off momentarily.
- Step 5 - Normal operation will resume:
  - 10 seconds after the last button is pressed.
  - OR
  - If the Air Ride Logo Button is pressed.



## Troubleshooting Guide

Problem	Symptom	Possible Cause	Possible Solution
Compressor will not turn on.	12 volts are measured on the red wire at the compressor and it still will not turn on.	<ol style="list-style-type: none"> <li>1. Poor compressor ground.</li> <li>2. Faulty connection between battery and compressor.</li> <li>3. Bad compressor.</li> </ol>	<ol style="list-style-type: none"> <li>1. Make sure there is a clean connection directly to the frame.</li> <li>2. Even though there is 12v at the compressor there may not be sufficient amperage.</li> <li>3. Replace the compressor.</li> </ol>
Faulty relay.	Compressor will not turn on and there is 12v at the small red wire on the relay but not at the white wire.	Faulty connection or low battery voltage.	Test battery and check all connections between the battery and comp. ground. Replace relay.
Blown fuse	Compressor will not turn on and 12v are measured on the battery side of the fuse but not on the comp. side.	<ol style="list-style-type: none"> <li>1. Low battery voltage.</li> <li>2. Faulty connection. The spades at the pressure switch sometimes become loose. (Low voltage will cause a high amp. draw.)</li> <li>4. Wrong size fuse. The Thomas 327 needs a 20amp and the Viair 400 needs a 30 amp.</li> </ol>	<ol style="list-style-type: none"> <li>1. Test battery.</li> <li>2. Fix connections or tighten spades.</li> <li>3. Replace fuse</li> </ol>
One air spring leaks down over a period of time.	Use soapy water in a spray bottle to help find leaks. You can also switch the delivery lines at the valve to determine weather the leak is at the valve or at the air spring.	<ol style="list-style-type: none"> <li>1. Leak at one of the fittings or airlines.</li> <li>2. Exhaust valve is leaking. Usually due to dirt stuck on the seat.</li> <li>3. Air spring is leaking. (Check the fittings first, it is almost always the problem.)</li> </ol>	<ol style="list-style-type: none"> <li>1. Tighten fitting or reseal with more thread sealant. Replace fitting if needed.</li> <li>2. Cycle that valve up and down numerous times. Blow valve out with shop compressor.</li> <li>3. Replace air spring.</li> </ol>
All 4 air springs leak down over a period of time.	Usually the air springs with more pressure will start to drop first.	There is a leak in the supply side of the system. This could be at the comp. , tank, or supply ports on the valve.	Fix leak.