

g-Bar - VariShock Air Springs

Air-spring equipped vehicles offer some additional benefits. Besides proven excellence in handling performance, you also have the advantage of excellent ride characteristics, and the ability to set your vehicle on the ground for jaw-dropping, static displays.



Part Number	Description	Price
5801-XXX	g-Bar rear air suspension, 1964-70 Mustang/Cougar	\$2199-up

Rear Pushrod Suspension

The TCP Rear Pushrod Suspension System enables dramatically improved handling performance for Classic Mustangs and Fords in a high-tech, self-contained package. We've replaced the leaf springs with double-adjustable VariShock coil-over shocks, tubular trailing arms, watts link assembly, and heavy-duty torque arm. The result is consistent, predictable handling suitable for the most demanding of performance applications. Additional benefits include significant improvement to chassis rigidity and extremely precise tuning adjustments such as ride height, wheel base, housing alignment, instant center, pinion angle, shock valving, as well as a choice of spring rates.

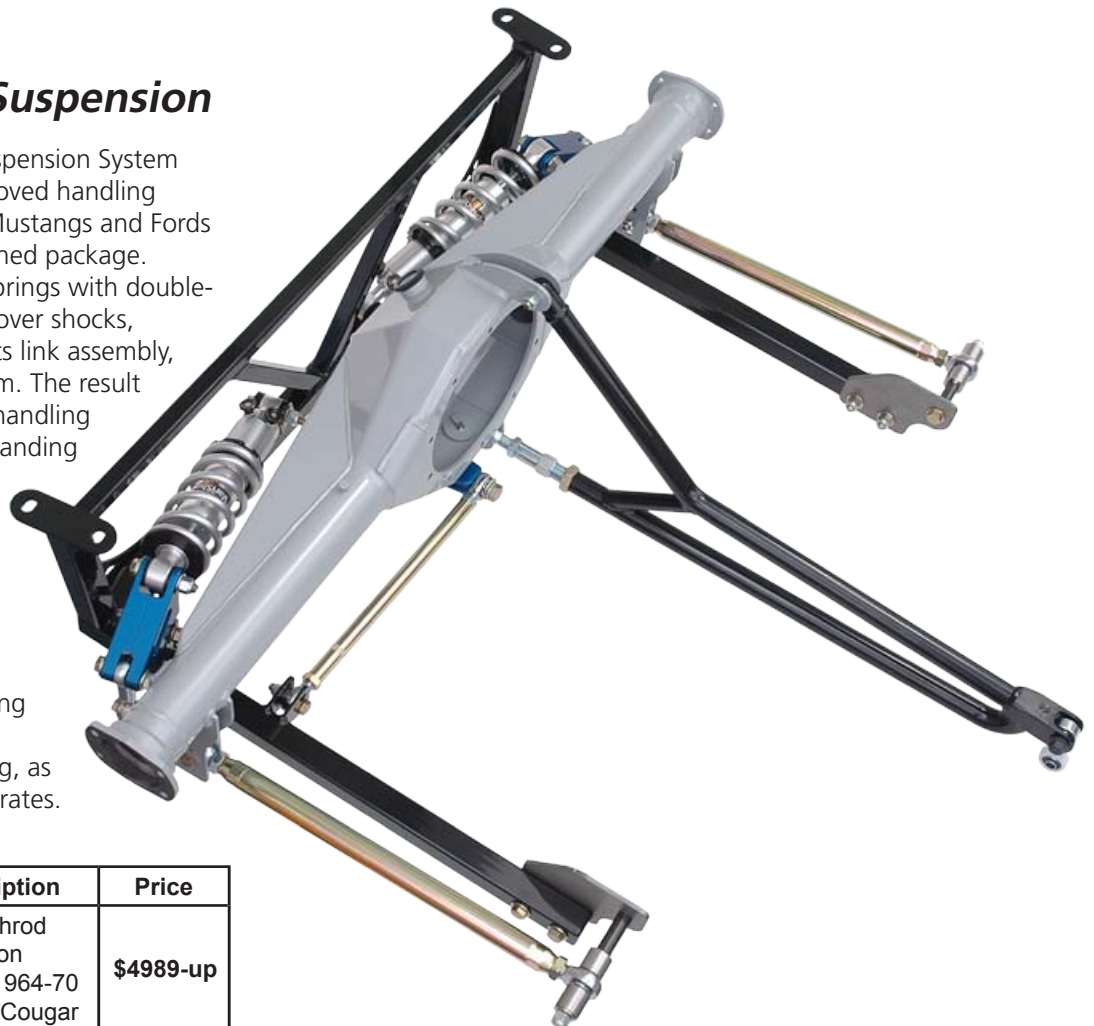

Part Number	Description	Price
TCP RPSS-FD	Rear pushrod suspension system, 1964-70 Mustang/Cougar	\$4989-up