

REAR SUSPENSION

Direct-Fit FAB9™ Rearend Housings

Total Control Products is proud to offer Chassiswork's direct-fit, FAB9™ fabricated 9" rearend housings. Engineered to accept all 9", Ford-style differentials, each FAB9™ includes a fully-welded center section with internal gussets, 3" axle tubes, and Ford big-bearing, late-model Torino, housing ends. All housings are manufactured in-house utilizing our state-of-the-art robotic spray-arc welder. Weld penetration, and quality are absolutely outstanding, guaranteeing consistent, reliable performance. Center sections are fully CNC-machined after welding to provide an excellent third-member-seal surface and extremely tight tolerances on the remaining housing features. Optionally, a folded back brace assembly can be factory welded to your FAB9™ housing, substantially strengthening the housing without adding significant weight. Standard housings are constructed from mild steel, but can be upgraded to 4130 chromemoly; recommended for vehicles weighing over 3500 lbs., and/or developing 650-plus horsepower. Housing hardware includes: billet-aluminum, o-ringed filler/inspection cap; axle-tube vent; magnetic drain plug; and alloy-steel, 12-point, mounting studs with locknuts.

g-Bar Direct-Fit FAB9™ Housings

Total Control's g-Bar FAB9™ offers exceptional performance, reliability, and adjustability in a bolt-on, factory-welded housing, complete with all suspension brackets. Housings are engineered for proper clearance using either VariShock coil-overs or ShockWave® air suspension; with or without a back brace. Anti-roll-bar bracket options include chassis-mounted (sliding-link bar), axle-housing mounted (splined-end bar), or no anti-roll-bar brackets installed.

Narrowed Housing Widths

Housings can be built to standard widths for OEM wheel offsets or narrowed to accommodate wider tire and wheel combinations. Widths can be narrowed in 1/4" increments to a wheel-to-wheel minimum of 55-1/4" (2" less than factory for 1965-1966 Mustang, and 4" less for 1967-1970 Mustangs and Cougars. Complete correct length axle packages and third members are also available. Ask our sales representatives for details.

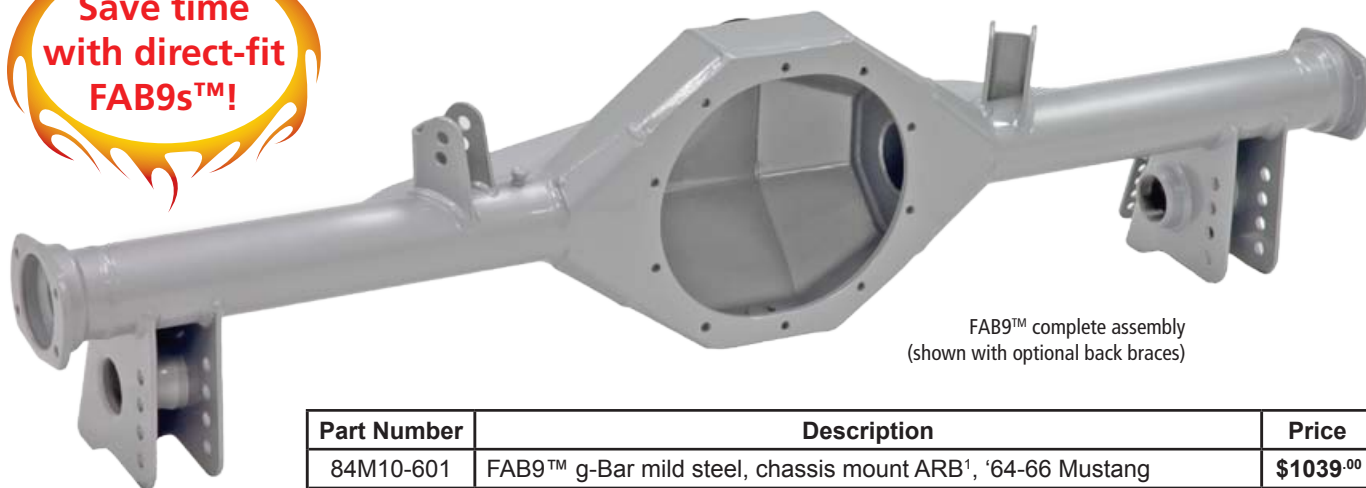

FAB9™ complete assembly (shown with optional back braces)

Part Number	Description	Price
84M10-601	FAB9™ g-Bar mild steel, chassis mount ARB ¹ , '64-66 Mustang	\$1039 ⁰⁰
84M10-611	FAB9™ g-Bar 4130, chassis mount ARB ¹ , '64-66 Mustang	1439 ⁰⁰
84M10-701	FAB9™ g-Bar mild steel, housing mount ARB ² , '64-66 Mustang	1089 ⁰⁰
84M10-711	FAB9™ g-Bar 4130, housing mount ARB ² , '64-66 Mustang	1489 ⁰⁰
84M20-601	FAB9™ g-Bar mild steel, chassis mount ARB ¹ , '67-70 Mustang/Cougar	1039 ⁰⁰
84M20-611	FAB9™ g-Bar 4130, chassis mount ARB ¹ , '67-70 Mustang/Cougar	1439 ⁰⁰
84M20-701	FAB9™ g-Bar mild steel, housing mount ARB ² , '67-70 Mustang/Cougar	1089 ⁰⁰
84M20-711	FAB9™ g-Bar 4130, housing mount ARB ² , '67-70 Mustang/Cougar	1489 ⁰⁰
OPTIONS	Folded back brace, mild steel, factory installed	150 ⁰⁰
	Folded back brace, 4130, factory installed	250 ⁰⁰
Footnotes:		
1	Chassis mount - Sliding-link adjustable anti-roll bar (5812-M10)	
2	Housing mount - Splined-end tubular anti-roll bar (5806-M10)	